

# Odosense<sup>®</sup>

Odour Monitoring System



# About Odosense®



Odosense® is an odour monitoring system designed to detect and measure a wide range of odorous gases, even at extremely low concentrations. It continuously monitors critical odorous parameters, offering a complete overview of ambient air quality. The device operates on Oizom's patented e-breathing technology, a micro-active sampling method that enhances data accuracy and stability.

Odosense® integrates seamlessly with Oizom's environmental monitoring platform, Envizom™, where data can be visualised in real-time in multiple units, including ppm, ppb, mg/m<sup>3</sup>, and OU (odour units). The platform also leverages AI and machine learning algorithms to ensure precise odour mapping and analysis. Equipped with smart features, Odosense® enables proactive odour management, which is useful for various applications, such as wastewater treatment plants, landfills, and the oil and gas industries.



## Product Features



### Patented Technology

Works on innovative e-breathing technology for higher data accuracy.



### Weather Resistant (IP 66)

IP 66 Grade (certified) enclosure for endurance against harsh weather conditions.



### Fully Solar Powered

The system works 100% on solar power, making it ideal for off-grid locations.



### Tamper Proof

Comes with a secure system to avoid tampering /malfunction/sabotage.



### Retrofit Design

Designed for seamless integration and easy deployment in existing infrastructure.



### Over-The-Air Update

Automatically upgradeable from a central server without any onsite visit.



### Compact

Lightweight and compact system that can be easily installed on a pole or wall.



### Internal Storage

Internal data storage capacity of up to 16 GB or 90 days.



### Relay Based Automation

Relay-based automation allows activating odour neutralisers when an odour level crosses thresholds.



### Network Agnostic

Supports a wide range of connectivity options like GSM / GPRS / WiFi / LoRa / NBIoT / Ethernet / Modbus / Relay.



### 3-Level Calibration

Our devices go through 3-level calibration, including lab calibration, colocation, & on-site calibration as per the U.S. EPA guidelines.



### On-device Calibration

On-site device calibration capability using devices' built-in calibration software.

# Key Benefits



**Detect Emission Source**  
Help industries track odorous gases and the sources of toxic pollutant emissions.



**Advanced TVOC detection**  
Monitor up to 720+ VOCs along with BTEX & HC gases through indicative values for detailed and accurate data on air quality.



**Monitor Multiple Parameters**  
Compatible with a wide range of parameters, including Gases and Meteorological parameters



**Accurate Data**  
Gives accurate readings in real-time to detect ppb concentrations in ambient air.



**Complain Management**  
Users can raise complains on the Envizom™ Platform for authorities to log issues and take actions.



**Custom Dispersion Modelling**  
Based on emissions and meteorological data, the custom odour calculative index provides accurate odour units for effective odour and dispersion modelling.

## Odosense® Usecases



### Wastewater

Monitoring odour intensity at waste water treatment plants can help regulate odour emission by appropriate maintenance on time.



### Landfills

Diffusion of odourful gases from landfills can create nuisance in the neighborhood. The odour level can be monitored to carry out precautionary steps.



### Oil and Gas

Ensure a safe work environment in oil and gas refineries by actively monitoring odorous gas levels at various refinery processes.



### Industries

Odourful gaseous emissions from industries like agrochemical, pharmaceutical, paper-pulp, and sugar, can be monitored to make data-driven measures for minimising their harmful effects.

# Odosense® Variants

Variants	Applications	Parameters
Odosense® Lite	STP, WWTP	SO <sub>2</sub> , H <sub>2</sub> S, NH <sub>3</sub> , Temperature, Humidity, Pressure
Odosense® Smart	Solid Waste	SO <sub>2</sub> , H <sub>2</sub> S, NH <sub>3</sub> , CH <sub>3</sub> SH, TVOC, Temperature, Humidity, Pressure
Odosense® Pro	Industrial, ETP	SO <sub>2</sub> , H <sub>2</sub> S, NH <sub>3</sub> , CH <sub>3</sub> SH, TVOC, CH <sub>2</sub> O, NO <sub>2</sub> , Cl <sub>2</sub> , Temperature, Humidity, Pressure
Odosense® Custom	As per request	Choice of upto 9 gases with THP and External Modules.

## Parameters

Sensors	ID	Range	Resolution	Min. Detection	Drift	Working Principle	Expected Sensor Life	
Sulfur Dioxide (SO <sub>2</sub> )	OZSO2_1*	0-10 ppm	0.001 ppm	0.01 ppm	±20 ppb / Year	Electrochemical	2 years	
	OZSO2_2	0-100 ppm	0.2 ppm	0.2 ppm	< 2% / Month			
	OZSO2_3	0-2000 ppm	5 ppm	5 ppm	< 2% / Month			
Hydrogen Sulfide (H <sub>2</sub> S)	OZH2S_1*	0-1.5 ppm	0.001 ppm	0.01 ppm	±100 ppb / Year			
	OZH2S_2	0-50 ppm	0.05 ppm	0.05 ppm	< 2% / Month			
	OZH2S_3	0-200 ppm	0.2 ppm	0.2 ppm	< 2% / Month			
	OZH2S_4	0-2000 ppm	2 ppm	2 ppm	< 2% / Month			
Ammonia (NH <sub>3</sub> )	OZNH3_4*	0-10 ppm	0.015 ppm	0.015 ppm	< 10% / Year			
	OZNH3_2*	0-100 ppm	0.3 ppm	0.3 ppm	< 2% / Month			
	OZNH3_3	0-1000 ppm	2 ppm	2 ppm	< 2% / Month			
Methyl Mercaptan (CH <sub>3</sub> SH)	OZCH3SH_1*	0-10 ppm	0.1 ppm	0.1 ppm	< 2% / Month			
Total Volatile Organic Compounds (VOC)	OZTVOC_1*	0-40 ppm	0.001 ppm	0.005 ppm	N.A.	Photo Ionization Detection (PID)	2 years#	
	OZTVOC_2	0-200 ppm	0.1 ppm	0.1 ppm	N.A.			
Formaldehyde (CH <sub>2</sub> O)	OZCH2O_1*	0-10 ppm	0.05 ppm	0.05 ppm	< 2% / Month	Electrochemical	2 years	
	OZCH2O_2	0-50 ppm	0.1 ppm	0.1 ppm	< 2% / Month			
Nitrogen Dioxide (NO <sub>2</sub> )	OZNO2_1*	0-10 ppm	0.001 ppm	0.01 ppm	±20 ppb / Year			
	OZNO2_2	0-100 ppm	0.2 ppm	0.2 ppm	< 2% / Month			
	OZNO2_3	0-500 ppm	0.5 ppm	0.5 ppm	< 2% / Month			
Chlorine (Cl <sub>2</sub> )	OZCl2_1*	0-20 ppm	0.05 ppm	0.05 ppm	< 2% / Month			
	OZCl2_2	0 - 50 ppm	0.1 ppm	0.1 ppm	< 2% / Month			
Methane (CH <sub>4</sub> )	OZCH4_2	50-1,000,000 ppm	1 ppm	50 ppm	N.A.			MEMS
Hydrogen Chloride (HCl)	OZHCL_1	0-50 ppm	0.5 ppm	0.5 ppm	< 2% / Month			Electrochemical
	OZHCL_2	0-100 ppm	1 ppm	1 ppm	< 2% / Month			
Temperature	OZTEMP_1*	-40 to 125°C	0.01°C	-40 °C	N.A.	Resistive / Photoacoustic		
Humidity	OZHUM_1*	100% Rh	0.10%	0.10%	N.A.			
Pressure	OZPRES_1*	300-1100 hPa	0.18 Pa	300 hPa	N.A.			
Chlorine Dioxide (ClO <sub>2</sub> )	OZCLO2_1	0-1 ppm	0.05 ppm	0.05 ppm	< 2% Signal/Month	Electrochemical		
BTEX	OZBTEX_1	0-10 ppm	0.001 ppm	0.001 ppm	N.A.	Photo Ionization Detection (PID)	2 years #	
Hydrocarbon / NMHC	OZHC_1	0-20 ppm	0.001 ppm	0.005 ppm	N.A.		2 years #	

# TVOC, BTEX & HC Sensor Housing: 2 years, TVOC, BTEX & HC Lamp is user replaceable: 10,000 hours

Expected Sensor Life can vary, subject to actual concentration on-site. In the interest of continued product improvement, we reserve the right to change design features and specifications without prior notification. The data contained in this document is for guidance only, Oizom® accepts no liability for any consequential losses, injury or damage resulting from the use of this document or the information contained within.

### External Modules

 <p><b>Anemometer</b> OZWSD_1*, OZWSD_2 <b>Wind Speed:</b> 0-40 m/s; 0-80 m/s <b>Wind Gust:</b> 0-40 m/s <b>Wind Direction:</b> 0-359° <b>Working Principle:</b> Ultrasonic</p>	 <p><b>Rain Gauge</b> OZRAIN_1, OZRAIN_2* <b>Resolution:</b> 0.25 mm; 0.1 mm <b>Working Principle:</b> Tipping Bucket</p>	 <p><b>Noise Sensor</b> OZN_2* <b>Working Principle:</b> Capacitive <b>Range:</b> Upto 140 dB</p>	 <p><b>Vibration Sensors</b> PPV: +/- 2G <b>Range frequency:</b> 0.5 - 250 Hz <b>Range velocity:</b> ±50 mm/s (±2 in/s) <b>Working Principle:</b> MEMS</p>
---	--	--	---

\* Indicates standard delivery timeline

# Specifications

## Mechanical

Size	360mm (H) x 328mm (W) x 200mm (D)
Weight	8 Kg (instrument weight)
Material	Aluminum magnesium alloy, mild steel (with powder coating), FRP
Certifications	CE, FCC, NEMA 4X, IP66, RoHS, PTCRB, ICASA

## Electrical

Avg. Power Consumption	Up to 7 Watt (Actual consumption will vary upon the number of parameters)
Power Input Options	AC : External 110-240V AC, 50-60Hz DC : Uninterrupted 24V DC, 2 Ampere 100 Watt 24V Solar Panel
SMPS Specs	24V, 2Amps output UL-62368 & CAN/CSA C22.2 Certified
Battery Backup Time	Up to 24 Hours
Battery Specs	Lithium iron phosphate (LiFePO4) battery with rated voltage 12.8V Capacity

## Technical

Processor	Quad Core ARM Cortex
Memory	2GB RAM / 16 GB eMMC ROM
Device Interface	On-device Software / API / Cloud Platform
Internal Data Storage	Up to 16 GB or 90 days

## Environmental

Operating Temperature	-20 °C to 60 °C
Operating Humidity	0-93% RH
Recommended Temperature	-20 °C to 45 °C
Recommended Humidity	20-90% RH
Storage Conditions	10 - 40°C









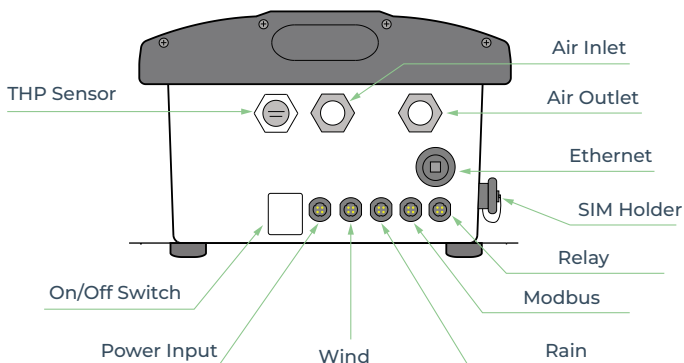

## Sensing

Gas Measurement Principle	Active Sampling with Sampling rate of 325 mL/Sample
Warm up time	< 48 hours for data stabilisation

## Communication

Data Interval	2-30 minutes (configurable)
Data-push Protocol	HTTPS post request to host server
Data-pull	HTTPS request on device IP
Firmware Updates	Over-The-Air Firmware Update
Standby Connectivity	GSM (2G/3G/4G) for remote diagnosis, FOTA updates, and cloud calibration



	Connectivity Options	Specification
Wireless	 GSM	Global 2G / 3G / 4G
	 LoRa	868 MHz / 915 MHz
	 LTE	CAT-M1
	 NB-IoT	CAT-NB1
	 sigfox	868 to 869 MHz, 902 to 928 MHz
	 Wi-Fi	AP Mode and Station Mode
Wired	 Satellite	
	 Ethernet	Static / DHCP Configuration
	 Modbus	RS485 RTU / TCP
	 RELAY	2 Channel Relay Output

# Functional Specifications

Proper location selection is critical for optimised data collection. It varies as per the purpose of the project. According to U.S. EPA QA handbook (Vol II, Section 6.0 Rev.1), the selection of locations should be based on monitoring purposes.

<b>Preferred Mounting</b>	Pole / Wall (preferably 270° open surrounding)
<b>Installation Height</b>	12-15 feet (4-5 meters)
<b>Direction</b>	As per maximum direct sunlight exposure
<b>Power Availability</b>	Constant AC / DC supply within a 2-meter range from the unit or solar panel
<b>Network Availability</b>	Uninterrupted network connection

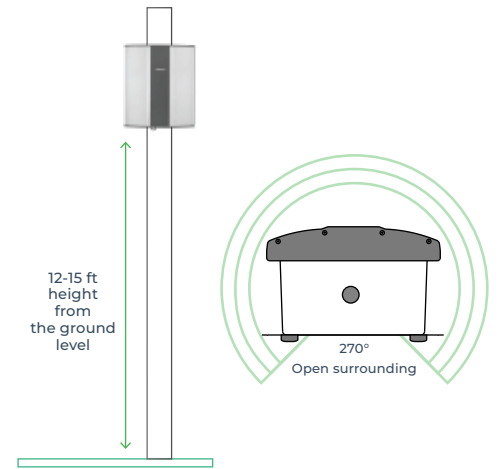

# Solution Architecture

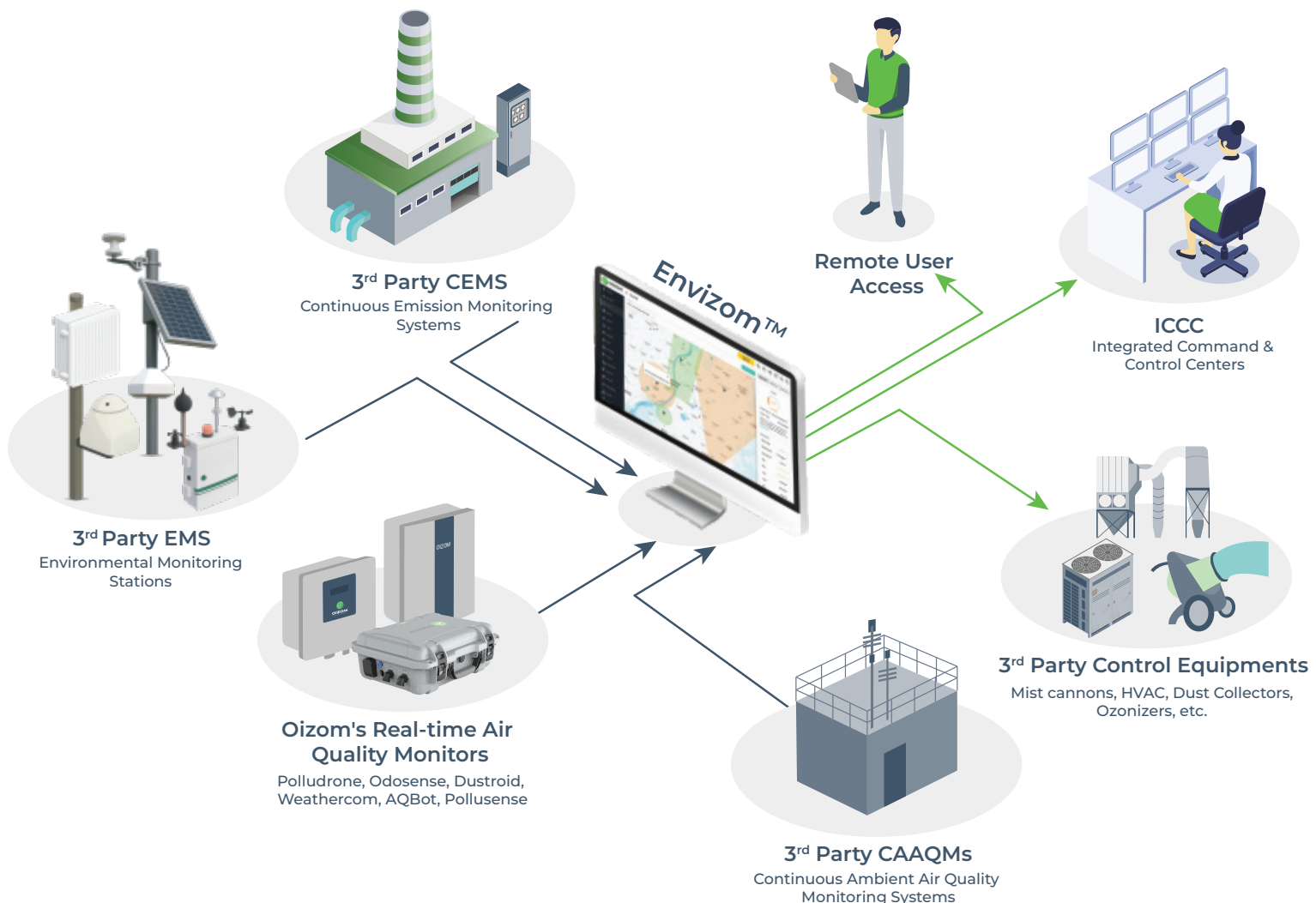

# Envizom™

## Data Visualisation and Analytics Platform



Envizom™ is Oizom's Environmental visualisation & analytics platform, built to turn complex air quality data into actionable insights. Providing remote visibility & control, it consolidates data from multiple sites, parameters, & devices into a single, intuitive dashboard. Our Environmental Data Interpretation Engine, powered by Artificial Intelligence & Machine Learning algorithms, provides accurate, real-time data, helps identify pollution sources, & understands directional trends. From city-wide comparisons to site-specific trends, smart multi-dimensional analytics enable comparisons across locations, parameters, & time spans. Envizom™ uses secure servers for data storage and on-premise storage is also supported.

Envizom's Cluster module allows users to monitor and analyze the odour data of industrial zones and nearby areas. The Complain module keeps users notified of air quality complaints in nearby areas and helps them to take immediate action to solve the problem quickly.

## Envizom™ Capabilities



Real-time Odour Data



Process Automation



Smart Alerts



Trend Analysis



Easy to Integrate



Report Module

## Privacy First Platform



Data Privacy



Data Ownership



Data Transparency

The data shared with the client uses an encryption server through Secure Socket layers. Envizom™ also uses AES encryption for connection that adds to data safety.

Envizom™ creates a secure and encrypted password combination for the user login. Oizom® ensures 100% privacy of the data and doesn't share without relevant permissions.

Data collected from Oizom® equipment runs through the Environment Data Interpretation Engine. It processes various algorithms and eliminates environmental impact interferences on the sensors.



SANS



IEC 62443-4-1



Security Tested



100w Cybersecurity Practices



TCM SECURITY

# Case Studies



## Dubai is Leading The Way to a Cleaner Future With Oizom's Odosense®

Oizom's Odosense® systems have been installed by Dubai Municipality across the city to monitor toxic and odorous gases in real-time. The data helps authorities take timely actions to maintain safe and healthy air quality.



UAE



Odosense Custom



Smart City

## Improving Landfill Air Quality at UAB VAATC with Odosense®

Oizom® installed the Odosense® system at UAB VAATC's landfill site, enabling real-time monitoring of odorous and toxic gases to help identify air quality trends and implement effective mitigation strategies.



Lithuania



Odosense Custom



Waste Management



## Real-time Monitoring of Harmful Gases at Epson India's Manufacturing Facility

Epson India adopted Oizom's Odosense® Smart to ensure a safe work environment and regulatory compliance. The system enables continuous monitoring of toxic gases, supporting proactive and data-driven decision-making.



India



Odosense Smart



Manufacturing Industry

# Case Studies



## Odosense Installed At SKUAST-Jammu For Odour Management in Livestock Farming

To enhance animal welfare and promote sustainable farming, SKUAST-Jammu implemented Oizom's Odosense® system. The device helps monitor odour levels in real-time, guiding better practices in livestock management and community health.



India



Odosense Custom



Livestock

## Air Quality Monitoring at The Mitsubishi Chemical Plant in The USA

Mitsubishi Chemical installed Oizom's Odosense® systems to monitor critical gaseous pollutants across its facility. The solution enables improved process control, regulatory compliance, and reduced operational risks.



USA



Odosense Custom



Chemical Industry



## Advancing Odour Monitoring in Metro Depot with Odosense®

ASA Bhanu Technical Services Ltd (ABTS) installed Oizom's Odosense® at the Gyaspur Metro Depot in Ahmedabad to monitor odour levels from a nearby wastewater treatment facility. This improved operational response ensured worker safety and strengthened environmental control at the site.



India



Odosense Custom



Industrial EHS



# Oizom<sup>®</sup> Gas Sensor

The Oizom<sup>®</sup> Gas Sensor (OGS) module is designed to accurately measure low concentrations of various gases at ppb, and ppm levels in the ambient air. The sensor is capable to monitor the point source gases on real-time basis. Each sensor is integrated into a metal casing along with the ultra-low-noise support electronics, which makes it compact and reliable. This allows accurate gas detection even at very low concentrations in the atmosphere.

1. Proprietary gas sensing technology
2. Independent calibration of each sensor
3. Low-noise electronic design

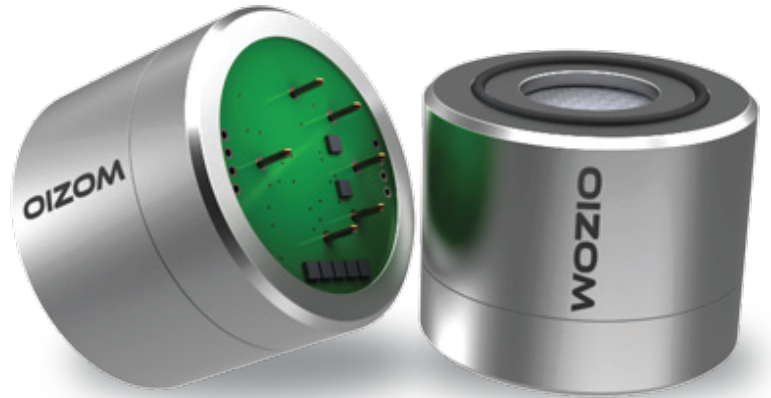

## Data and Calibration

### 1 Laboratory Calibration

All air quality monitoring systems are calibrated at the ISO/IEC 17025:2017 certified calibration laboratory using standard NIST traceable calibration gas standards as per the international guidelines by U.S. EPA. (Vol II, Section 6.0 Rev.1)



### 2 Collocation Calibration

Post lab calibration, the monitors are operated adjacent to a custom-built reference station housing U.S. EPA-designated Federal Equivalent Method (FEM)/Federal Reference Method (FRM) for collocation calibration to ensure optimum data quality.



### 3 On-site Calibration

On-site calibration of Oizom<sup>®</sup> devices can be performed using standard calibration gas cylinders of known concentration or by co-locating with a reference standard.



# About Oizom®



Leader in sensor based  
air quality monitoring



Monitors designed for  
easy and quick setup



Low powered solutions  
for multiple applications

Oizom® is an environmental company that offers accurate air quality monitoring solutions designed to deliver air quality insights for better decision-making. Using our patented e-breathing technology, we measure key environmental parameters including air quality, noise, odour, weather, radiation, etc. Our AI-enabled data analytics platform can derive various actionable insights and predict data for authorities, communities, and industries.

With a strong focus on data accuracy and reliability, our devices are powered by advanced technology and smart algorithms. From fixed installations to portable monitors, Oizom® offers scalable solutions that fit a wide range of applications, including construction, mining, industrial safety, smart infrastructure, and environmental compliance. Over the past decade, Oizom® has deployed over 3,500 environmental monitoring devices across 90+ major cities, helping track the environmental health of over 250 million people through a strong partner network in 80+ countries.

## Other Oizom® Products



### Dustroid®

Real-time Dust Monitor

Dustroid® is an online particulate monitoring system to measure various particulate matter sizes.



### AQBot™

Single Parameter Air Quality Monitor

AQBot™ is an industrial-grade single-parameter air quality monitor with automation capabilities.



### Weathercom®

Automatic Weather Station

Weathercom® is an automatic weather station designed to measure various meteorological parameters.



### Polludrone®

Ambient Air Quality Monitoring

Polludrone® is an ambient air quality monitor that measures particulate matter, gases, and weather parameters.



### Pollusense™

Portable Air Quality Monitor

Pollusense™ is a portable air quality monitor that measures multiple toxic gases and particulates.





Trusted by

**80+ Countries**



Solutions Installed in

**90+ Cities**



Total Devices Installed

**3500+**



Total Population Covered

**250 million+**

## Oizom Customers



WASTE CONNECTIONS  
*Connect with the Future*



**Changing the way Industries monitor air quality**



Get in touch



House No.2, Garden View Corporate House,  
Opp. Bodakdev Auda Garden, Ahmedabad, India

✉ [contact@oizom.com](mailto:contact@oizom.com) / [connect@oizom.com](mailto:connect@oizom.com)

☎ +91 88666 60025 / 39